

NOTE:  
TETHERS NEEDED IF APPLICATION REQUIRES  
FMVSS 207/210 TO BE MET.

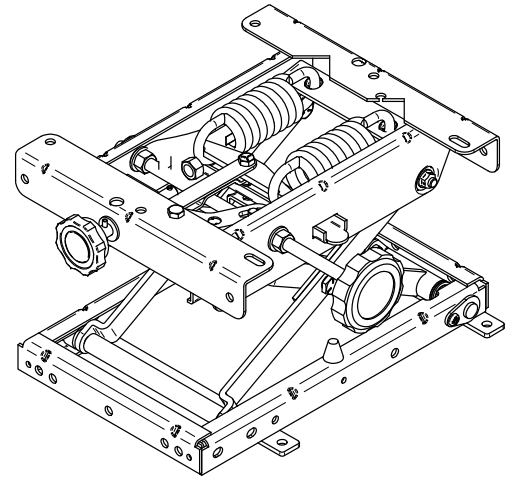
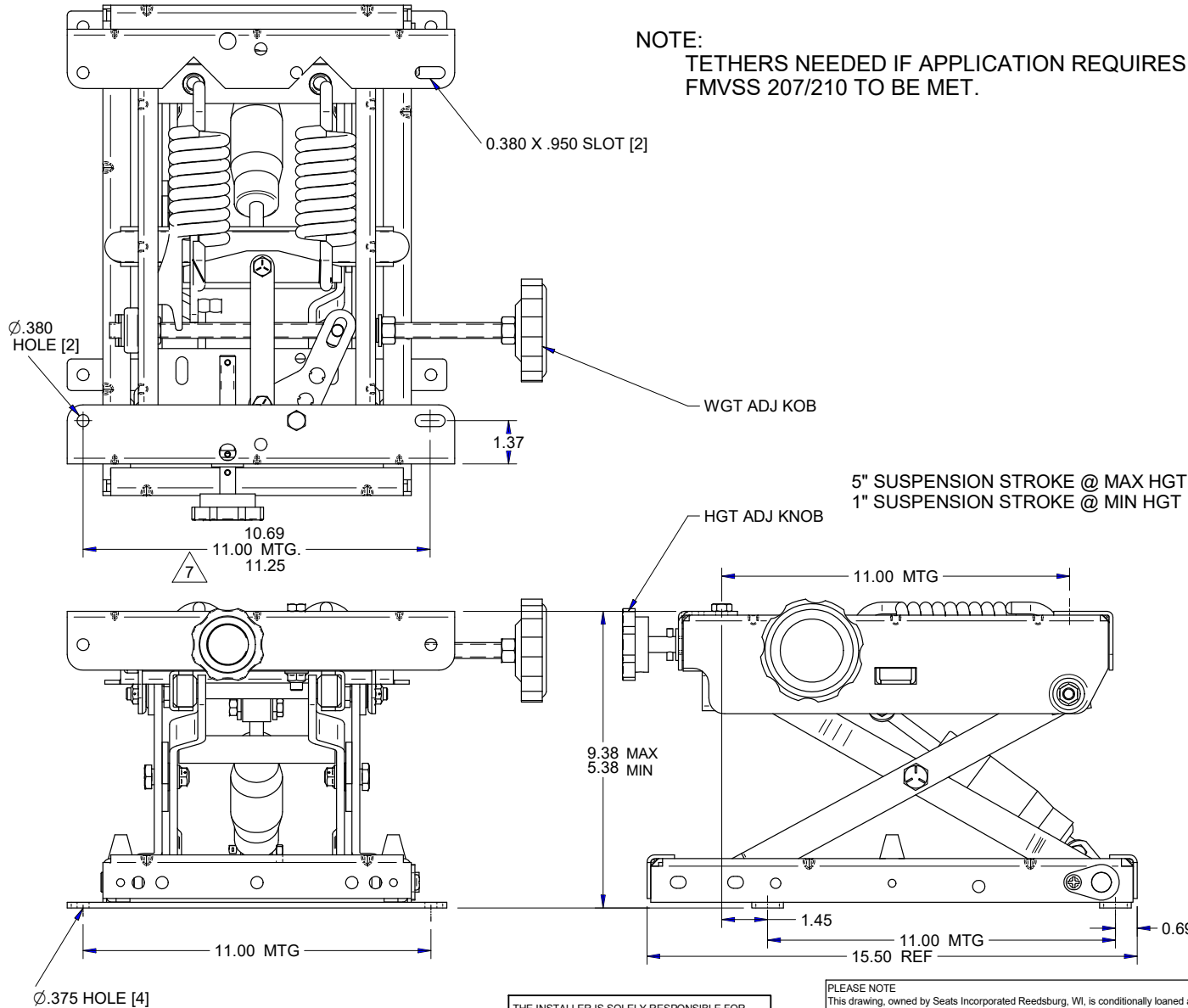

**\* DWG BEING REVISED \***

PLEASE SEE DWG: 132172-09  
PLEASE SEE: dcn  
BEFORE EDITING THIS DWG!  
REF ECR 113452

APPROX. EFF. DATE: pending tooling

REV	DESCRIPTION	DATE	APPROVED
8	MADE INTO DFT	08/16/2007	DCN
7	UPDATED AVAILABLE MOUNTINGS	03/10/99	DCN
6	ADDED SERVIC PART NUMBERS	12/09/06	DCN
5	UPDATED DWG W/ DIMS & REM.BOM	09/29/97	DCN
4	REM 707817,-816; 707131 WAS 707818.ADD 707664	01-13-95	DCN
3	UPDATE BOM & FROM E TO C SIZE	06-09-94	DCN
2	UPDATE BOM & PICTURE	02-04-92	ABA
1	WAS PN 707250	01-12-90	JWH

DIMENSIONAL TOLERANCES UNLESS OTHERWISE SPECIFIED:		REVISIONS	
3 PLACE DECIMALS ±	.010	 SEATS INCORPORATED PO BOX 60 REEDSBURG, WI 53959	
2 PLACE DECIMALS ±	.030		
1 PLACE DECIMALS ±	.50		
ANGLES ±	1.0°		
PUNCHED/DRIILLED FEATURES ± .003		TITLE	
DRAWN BY	DATE	MECH. LOW PROFILE SUSPENSION	
SBD	03-13-89	PART NO. 132172	
APPROVED BY	DATE	SIZE B	FSCM NO. 09704
FILE NAME: 132172-08.dft		DO NOT SCALE PRINT	
		SHEET 1 OF 1	

THE INSTALLER IS SOLELY RESPONSIBLE FOR  
DETERMINING THE SUITABILITY FOR USE  
OF THIS PRODUCT IN EACH APPLICATION

PLEASE NOTE  
This drawing, owned by Seats Incorporated Reedsburg, WI, is conditionally loaned and its disclosure to the recipient is in confidence. In receiving it, the recipient agrees not to reproduce or copy it in whole or part without written consent or to furnish information from it to others or to make any use of it that is, or may be injurious or damaging to Seats Incorporated in any way, and to return it immediately upon request. Seats Incorporated